

ECONO-PACK™

INTEGRATED ECONOMIZER

LOW COST CONTRACTOR FRIENDLY ECONOMIZER PACKAGE

The Econo-Pack™ is a complete economizer package that is easy for the contractor to install. A Carbon Dioxide (CO₂) sensor is also available as an option. The Econo-Pack™ can be supplied with or without the dampers.

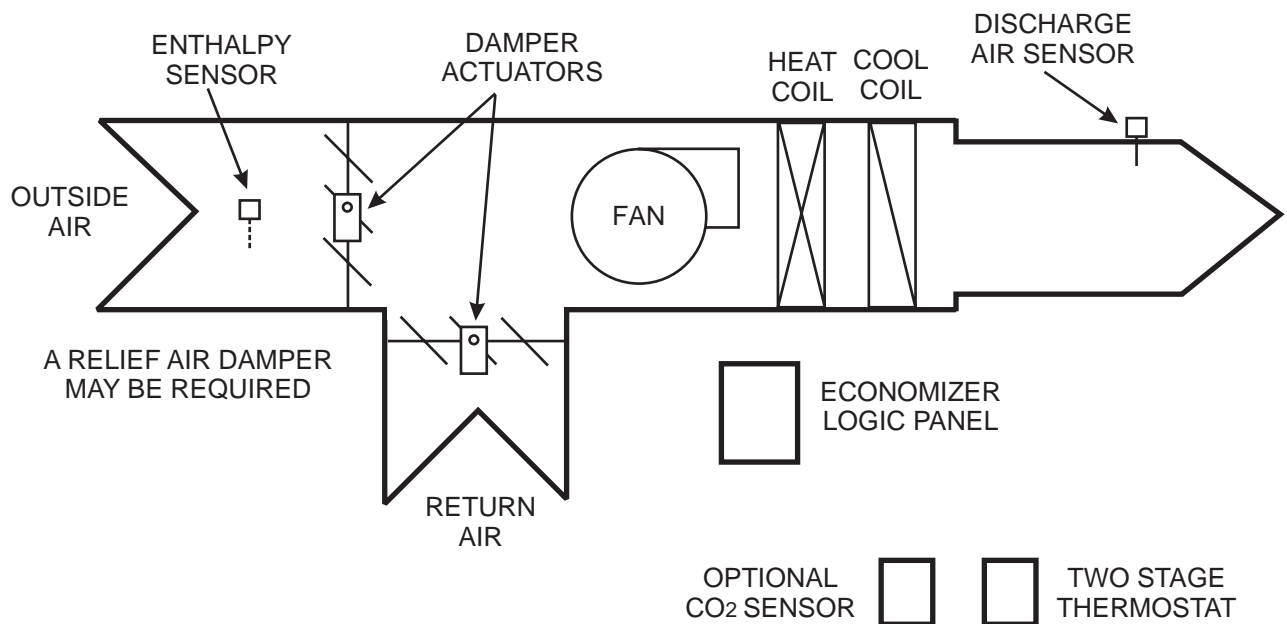

FEATURES:

- EASY TO INSTALL
- EASY TO SET UP AND ADJUST
- EASY-TO-READ WIRING DIAGRAM
- EVERYTHING NEEDED IN ONE PACKAGE

ECONO-PACK™

INTEGRATED ECONOMIZER

WIRING LAYOUT SHEET

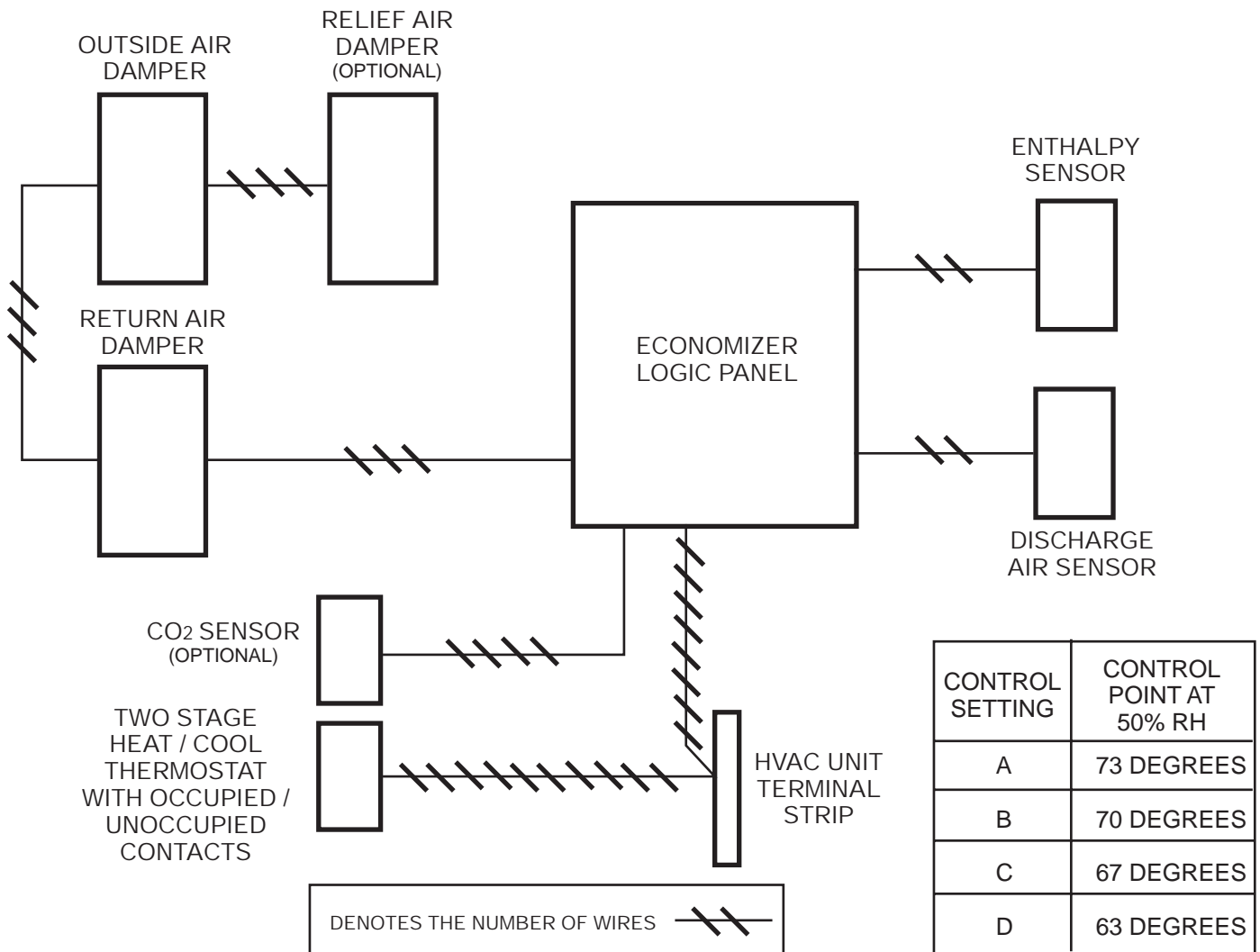

SEQUENCE OF OPERATION:

This economizer is integrated with the space thermostat and provides maximum energy savings during the cooling cycle by utilizing outside air for free cooling.

WHEN OUTSIDE AIR ENTHALPY IS BELOW SETPOINT (FREE COOLING)

1. The outside air damper is modulated open and the return air damper is modulated closed if the first stage of the thermostat is calling for cooling. The discharge air sensor will maintain a discharge air temperature between 50 and 56 degrees F.
2. First stage mechanical cooling is operated by the second stage of the thermostat.

WHEN OUTSIDE AIR ENTHALPY IS ABOVE SETPOINT

1. The outside air damper is driven to its minimum position adjustment.
2. A call for cooling from the space thermostat brings on the stages of mechanical cooling as required.
3. If a time clock is used, the outside air damper will be driven to the closed position during the unoccupied period.

ECONO-PACK™

INTEGRATED ECONOMIZER

WIRING DETAIL FOR MULTI-STAGE COMPRESSOR

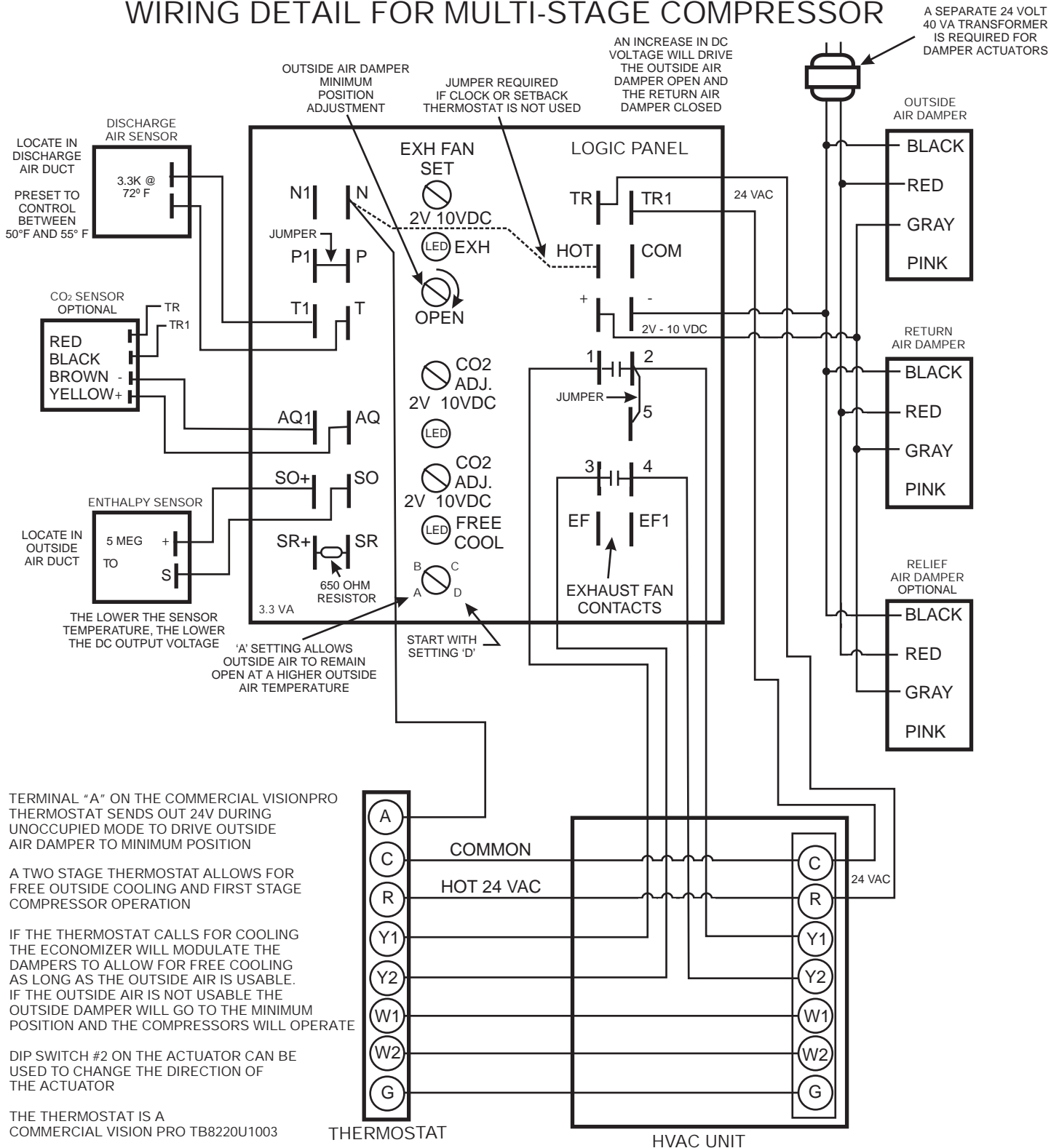

ECONO-PACK™

INTEGRATED ECONOMIZER

WIRING DETAIL FOR HEAT PUMP

A SEPARATE 24 VOLT 40 VA TRANSFORMER IS REQUIRED FOR DAMPER ACTUATORS

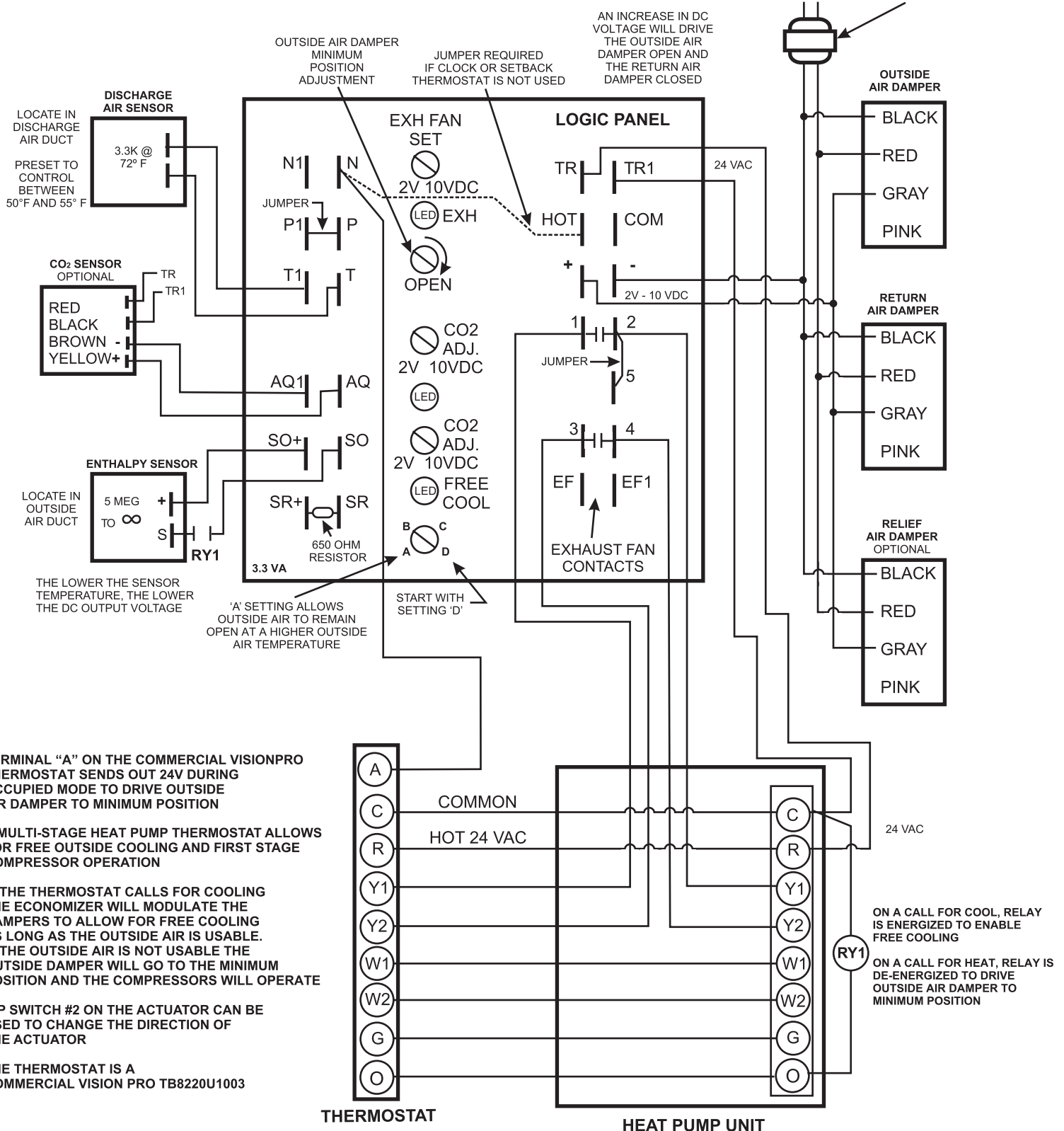

PERFORMANCE CHARACTERISTICS FOR ENTHALPY CHANGEOVER SETTINGS

CONTROL CURVE	CONTROL POINT APPROX °F AT 50% RH
A	73
B	70
C	67
D	63

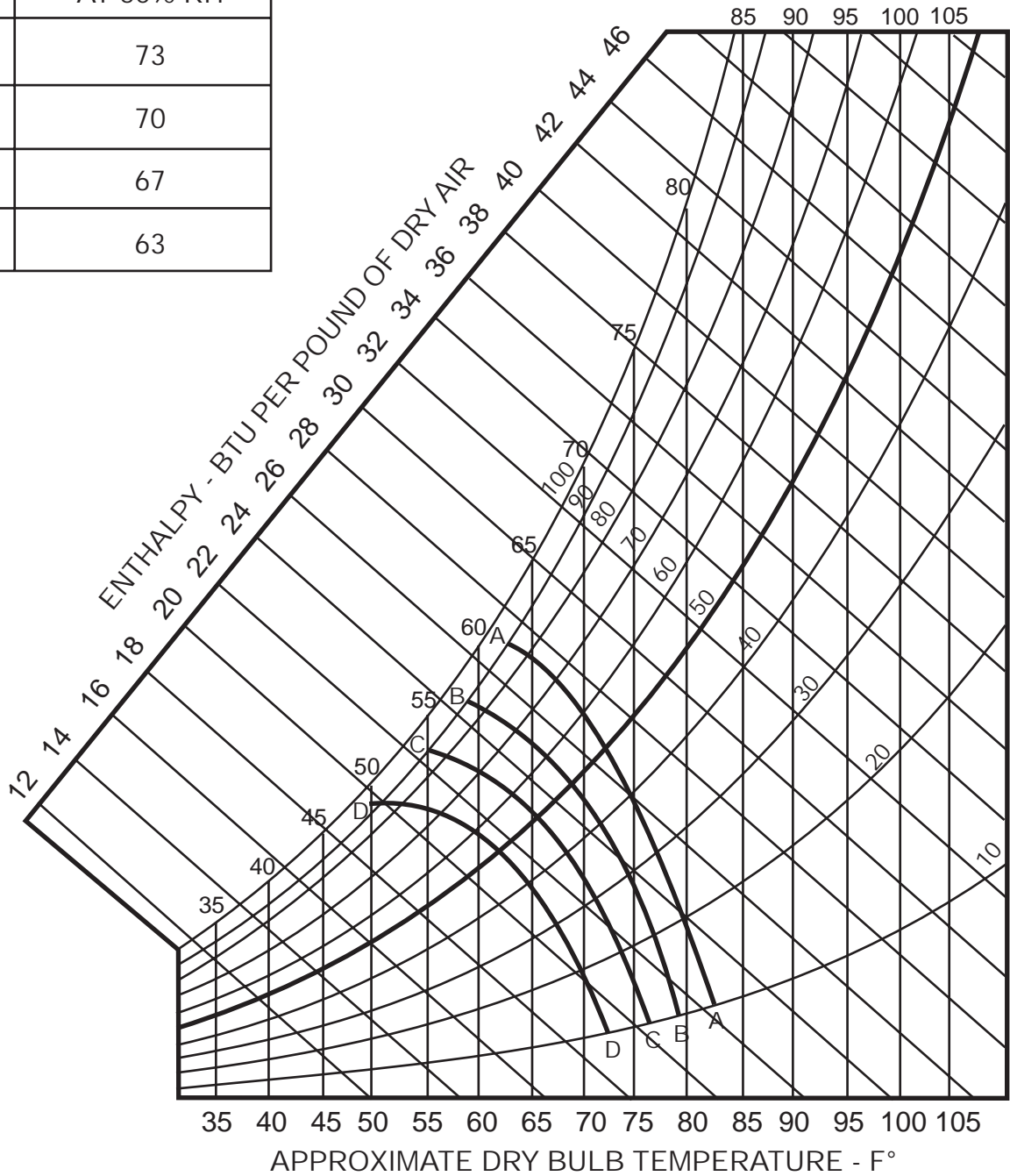

ECONO-PACK™ INSTALLATION GUIDE

MOUNTING THE DEVICES

Economizer Logic Module (EP-LM)

- Mount the logic module in a clean, dry area near the air handling unit (AHU).
- If the logic module is to be installed on a roof top unit (RTU), it must be in a weatherproof enclosure.

Enthalpy Sensor (EP-ES)

- Mount the enthalpy sensor outside on the north face of the building, or in the outside air duct near the intake air louver.
- Locate the enthalpy sensor in a location that will not be affected by the sun or other heat sources.

Dampers and Actuators

- Mount the outside air damper in the fresh air duct, near the intake air louver.
- Mount the return air damper in the return air duct near the AHU.
- If the damper actuators are outside, they must be in weatherproof enclosures.

Discharge Air Sensor (EP-DAS)

- Mount the discharge air sensor in the supply duct, down stream of the cooling coil.

Two Stage Thermostat with Occupied / Unoccupied Contacts

- Mount the room thermostat in a central location that will not be affected by the sun or other heat sources.

CO₂ Sensor - Optional (EP-CO₂-W or EP-CO₂-D)

- Mount the room CO₂ sensor in a central location near the room thermostat.
- Mount the duct CO₂ sensor on the return air duct near the AHU.

Control Transformer - 120 / 24 Vac, 40VA (TR-40)

- Mount the transformer in a 4" x 4" electrical box near a 120 volt power source.

ECONO-PACK™ INSTALLATION GUIDE

WIRING THE DEVICES

General Wiring Requirements

- All wiring must meet local and national codes.
- All wiring is 24 Vac (line voltage side of the transformer is 120 volts).
- Standard 18 gauge or plenum rated thermostat wire should be used for all low voltage wiring.
- See the Econo-Pack™ literature for more details.

Economizer Logic Module (EP-LM)

- Run 18/8 thermostat wire between HVAC unit and logic module.

Enthalpy Sensor (EP-ES)

- Run 18/2 thermostat wire between enthalpy sensor and logic module.

Damper Actuators

- Run 18/3 thermostat wire between damper actuators and logic module.

Discharge Air Sensor (EP-DAS)

- Run 18/2 thermostat wire between discharge air sensor and logic module.

Two Stage Thermostat with Occupied / Unoccupied Contacts

- Run 18/10 thermostat wire between room thermostat and HVAC unit.

CO₂ Sensor - Optional (EP-CO₂-W or EP-CO₂-D)

- Run 18/4 thermostat wire between CO₂ sensor and logic module

Control Transformer - 120 / 24 Vac, 40 VA (TR-40)

- Run 18/2 thermostat wire between the transformer and logic module.
- Run #14 THHN wiring between the 120V power source and the transformer.

Econo-Pack™ Test, Check and Start-up Guide

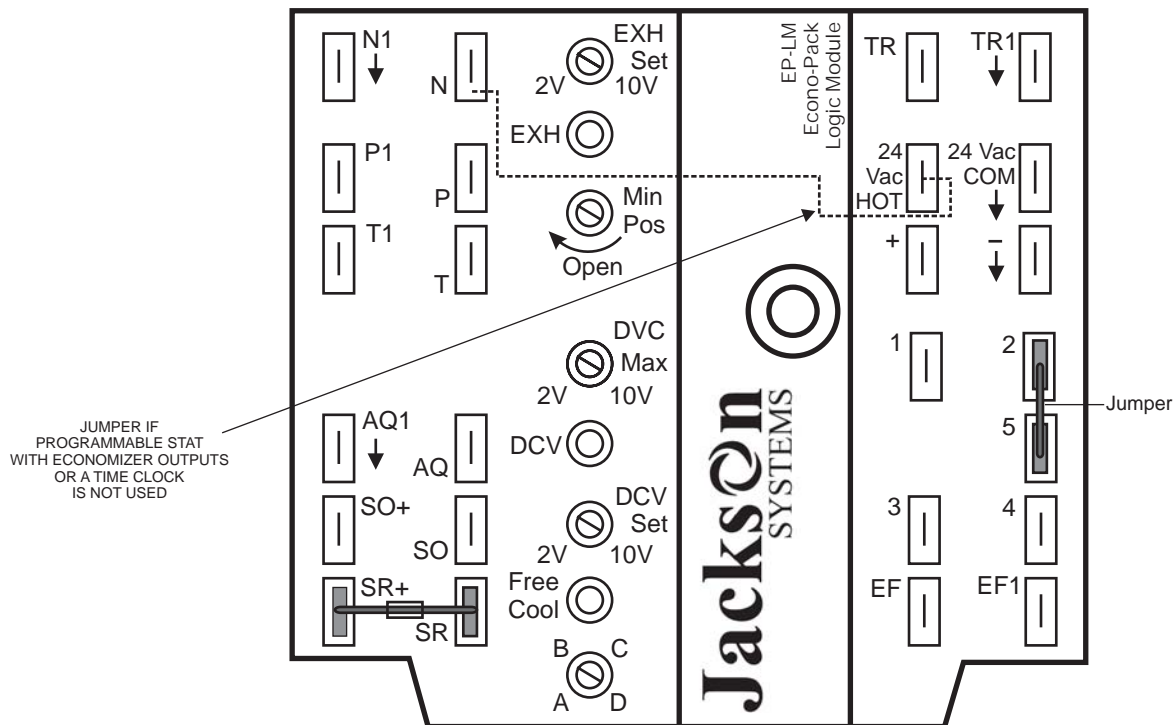

1. Confirm that a multi-stage thermostat or multi-stage zone control panel is being used.
2. Confirm that 24 Volt power is taken only from the HVAC equipment transformer and is connected to terminals TR and Tr1. The thermostat and logic board needs to be powered by this same transformer. Use a meter to confirm 24 volts AC on terminals TR and TR1.
3. Confirm that a separate 24 Volt transformer is being used for the damper actuators.
4. If a programmable thermostat with economizer outputs or a time clock is not used, confirm that a jumper is between N and 24 Vac HOT on the logic module.
5. With the free cool light off and the system is in the occupied mode, turn the adjusting screw marked Min Pos clockwise and counter-clockwise. This will vary the DC voltage (2-10 VDC) across terminals + and - and drive the actuators open or closed. If the actuators do not move, check the voltage across the gray and black leads on the motor. Turning the adjusting screw marked Min Pos clockwise will increase the DC voltage and drive the outside air damper open and the return air damper closed.
6. Temporarily disconnect the enthalpy sensor terminals and confirm that the outside air damper drives to minimum position. With the enthalpy sensor still disconnected, initiate a call for cooling at the thermostat and confirm that first stage mechanical cooling energizes. A call for second stage cooling from the thermostat should energize second stage mechanical cooling if the HVAC system is a two-stage or dual compressor system.
7. If the outside air is useable, the green LED marked Free Cool will be on based on the A B C D settings. A = 73° F, B = 70° F, C = 67° F and D = 63° F at 50% RH.
8. To check the discharge air sensor, disconnect it and use an ohm meter. The resistance should read 3.3 K ohms @ 72° F.